



VAV *Variable Air Volume Box*





Introduction

Used mainly in Green Buildings, the VAV Box maintains proper minimum airflow set points to ensure proper ventilation in a occupied space.

Unlike many VAV terminals which required the most ideal flow conditions in order to operate at their optimum, Prudentaire's VAV units are able to perform even at least ideal conditions (minimum 1D bend & 2D branch). Unlike many flow sensors, the unit's airflow sensor grid comes with 5 individual traverse lines connecting to a central averaging chamber to give a more accurate reading. This center averaging, which lacks in many VAV terminal units, is the single most important feature required for accurate airflow measurement.

To further add on to the accuracy of the measurement, the sensor locations followed closely to the ASHRAE recommendations on log-Tchebycheff rule (ISO 3966).

CONSTRUCTIONS & MATERIALS

Features

- Capacities ranging from 94 – 6925 CMH in 7 standard sizes
- Customizable sizes available
- Available with pneumatic or direct digital controls
- Pressure independent operation
- Can be used for VAV or constant volume applications
- Factory calibrated to job requirements
- Full range of accessories available (i.e. heating coils, attenuators, access, doors, etc.)

Base Unit Constructional Materials

- Damper casing : 0.6/0.7 mm thk GI metal according to VAV box size
- Modulating blade : Double layer 0.8mm GI Metal
- Acoustic cladding : 25mm thk, 32kg/m³ density fiber glass with matt black facing protection
- Shaft : 12.0mm thk GI round shaft
- Leakage seals : Anti-leakage rubber seals
- VAV actuator controller : Belimo (other brands available)



- Calibration Curves Verified By Datuk Ir. Prof. Dr Ow Chee Sheng
- Calibration Curves Verified By Ir. Yim Hon Wa
- Wind Tunnel In Accordance to AMCA-210 Standard
- Customizable Inlet and Outlet Spigots Sizes.

FUNCTION DESCRIPTION

Room Temperature Control

In VAV systems, room temperature is the primary controlled variable. Output signal from the room temperature controller is fed to the control circuit which in turn alters the required set point flow rate value of the supply air flow rate. Maintaining / changing room temperature takes the form of controlling the minimum and maximum flow rate limits of supply air to the occupied zone.

Upstream Flow Rate Measurement

The airflow sensor grid comes with 10 individual traverse lines (Front & back) connecting to a central averaging chamber to give a more accurate reading. Each traverse line consist of 3 pressure sensing ports (totaling 30 pressure sensing ports for each unit) located at strategic locations (in accordance to Log-Tchebycheff rule) to factor in the usual non-uniform airflow profile. With these key features, the sensor delivers the accurate pressure differential readings (velocity pressure) for supply airflow control purposes.

Air Flow Volume Control

Supply airflow volume varies with the changing system pressure, which pose a problem to pressure dependent VAV terminal units. Therefore in order to remove the dependence on system pressure, required control process is needed to maintain the much needed supply airflow volume, i.e. Measure – compare – maintain.

Pressure differential measurement taken is converted into an electrical signal, which is interpreted as the actual airflow value flowing through the unit. The controller compares the actual value with the set point value and alters the positioning of the damper blade with the reference to the value difference.

TECHNICAL PERFORMANCE DATA

SYSTEM ILLUSTRATIONS

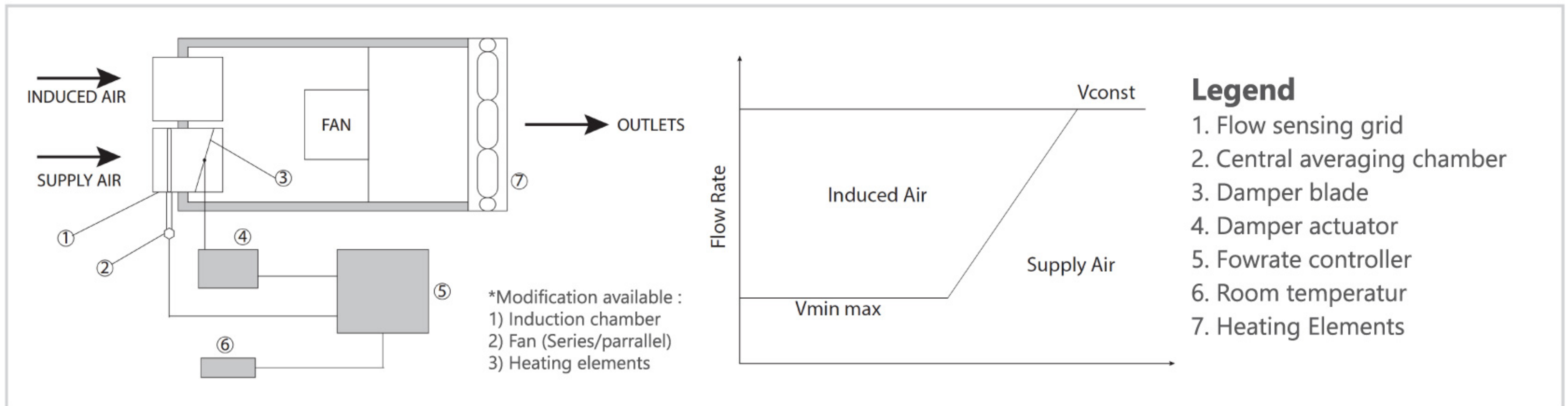
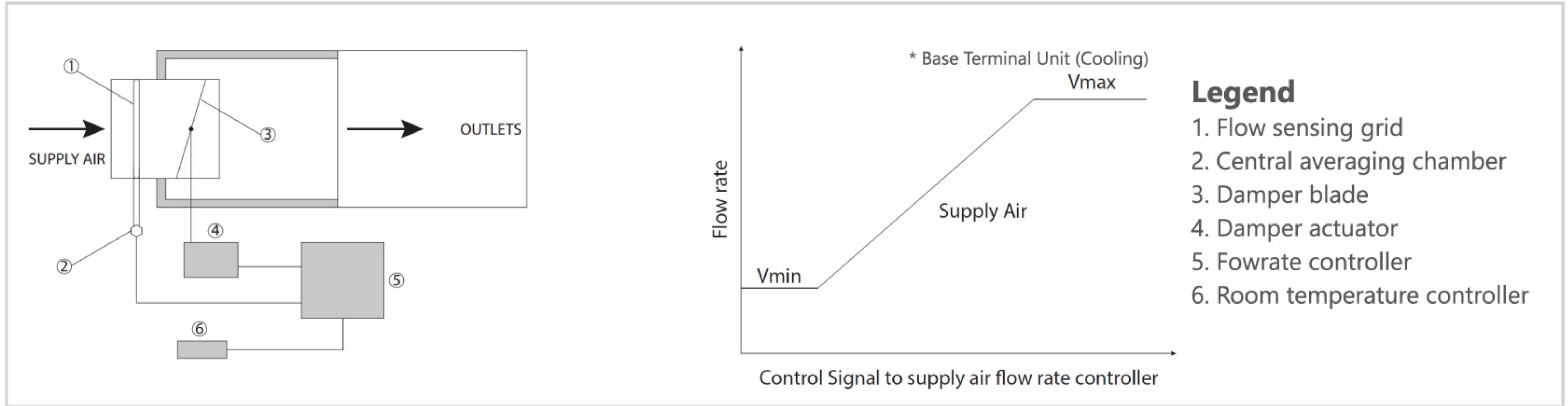

DIMENSIONAL DATA - BASIC UNIT

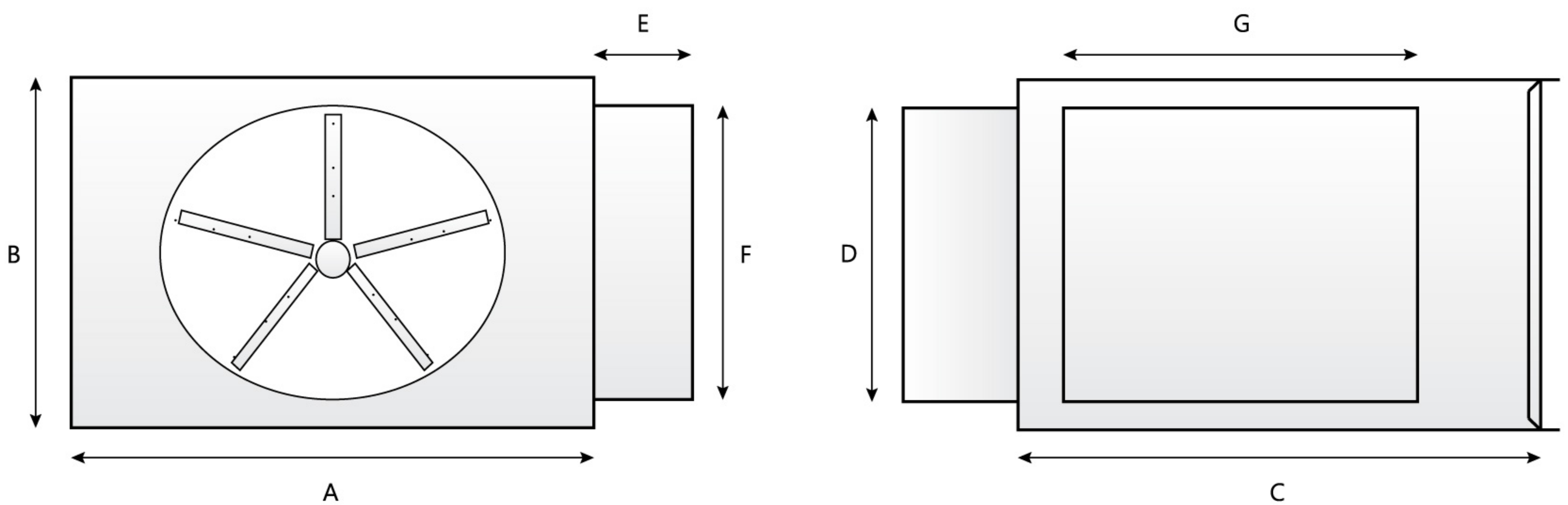

Order Size (inch)	A (mm)	B (mm)	C (mm)	D (mm)	E (mm)	F (mm)	G (mm)
4.0	310	210	390	99	125	210	355
5.0	310	210	390	124	125	210	355
6.0	310	210	390	152	125	210	355
8.0	310	255	390	203	125	210	355
10.0	360	320	390	254	125	210	355
12.0	410	385	390	305	125	210	355
14.0	510	445	390	356	125	210	355
16.0	615	455	390	406	125	210	355
24 x 16	965	455	380	606 x 403	125	210	355

ACCESSORIES

Electric Duct Heater

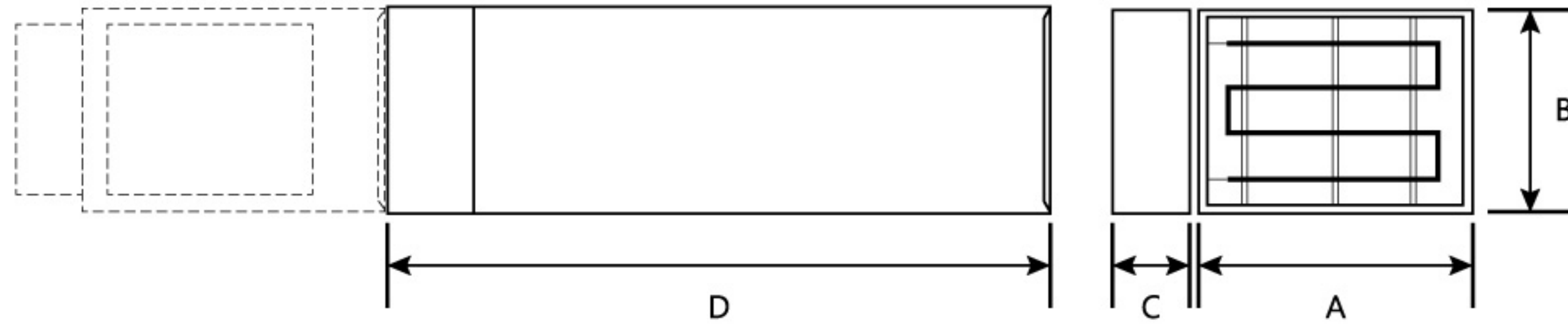

Order Size (inch)	A (mm)	B (mm)	C (mm)	D (mm)
4.0	310	210	152	700
5.0	310	210	152	700
6.0	310	210	152	700
8.0	310	255	152	700
10.0	360	320	152	700
12.0	410	385	152	700
14.0	510	445	152	700
16.0	615	455	152	700
24.0 x 16.0	965	455	152	700

Round Discharge Collar

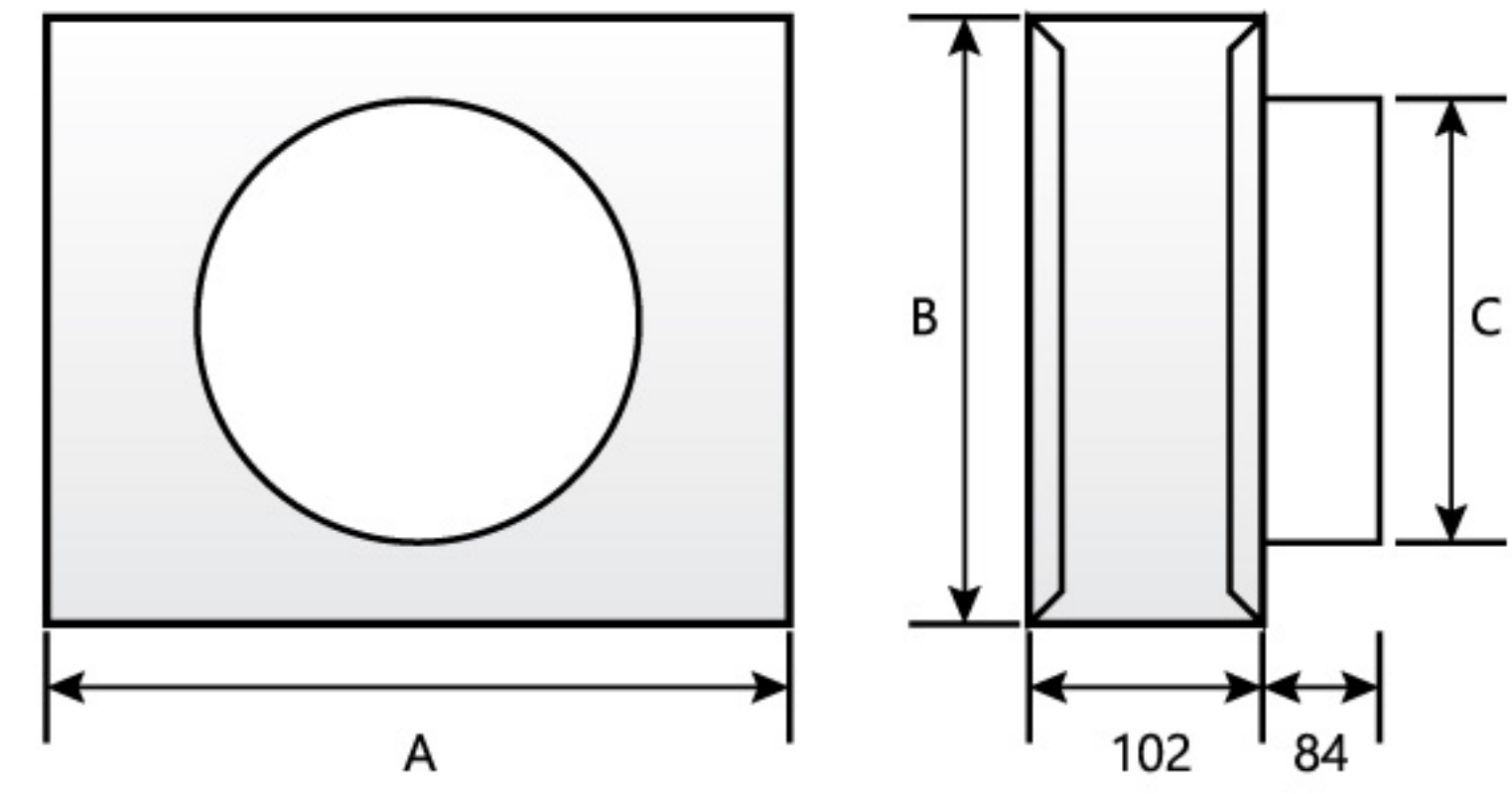

Order Size (inch)	A (mm)	B (mm)	C (mm)
4.0	310	210	99
5.0	310	210	124
6.0	310	210	152
8.0	310	255	203
10.0	360	320	254
12.0	410	385	305
14.0	510	445	355
16.0	615	455	406

INLET SENSOR PERFORMANCE CHART

Order Size (inch)	Air Volume Range (Min - Max)		
	l/s	CFM	CMH
4.0	21 - 94	44 - 200	75 - 340
5.0	31 - 165	65 - 349	111 - 593
6.0	35 - 258	75 - 547	127 - 930
8.0	47 - 472	100 - 1000	170 - 1700
10.0	75 - 750	159 - 1588	270 - 2700
12.0	103 - 1022	218 - 2164	370 - 3680
14.0	145 - 1455	305 - 3082	520 - 5240
16.0	195 - 1920	412 - 4070	700 - 6920
24 x 16	1842 - 3163	3900 - 6699	6630 - 11388

QUICK SELECTION GUIDE

Order Size (inch)	Airflow		Discharge NR			Radiated NR		
			Base unit / Δ Ps across unit					
	CMH	CFM	100 Pa	200 Pa	500 Pa	100 Pa	200 Pa	500 Pa
4.0	75	44	37	39	39	18	22	25
	124	73	43	45	47	23	28	29
	231	136	47	50	53	33	35	39
	340	200	53	56	58	39	43	47
5.0	111	65	35	35	42	17	20	27
	226	133	42	44	49	23	28	35
	410	241	49	51	57	33	37	45
	593	349	53	56	60	38	43	49
6.0	127	75	23	33	43	19	25	33
	372	219	29	34	45	23	30	40
	650	382	32	36	48	28	33	43
	930	547	33	40	51	31	36	44
8.0	175	103	23	33	42	19	25	29
	680	400	30	34	47	24	30	32
	1190	700	32	37	49	32	34	43
	1700	1000	33	40	52	37	38	46
10.0	270	159	25	33	46	18	25	33
	1080	635	33	37	48	29	33	41
	1890	1111	36	40	51	36	39	47
	2700	1588	39	42	55	41	43	51
12.0	370	218	27	33	49	18	24	32
	1470	865	36	39	54	29	36	43
	2575	1515	42	44	56	40	43	49
	3680	2165	62	48	58	47	50	54
14.0	525	309	30	35	50	20	24	44
	2090	1229	42	44	55	40	43	50
	3670	2158	52	54	59	48	50	56
	5240	3082	62	63	64	51	53	61
16.0	693	408	33	38	51	21	26	37
	2770	1629	48	50	55	36	47	51
	4850	2853	56	54	59	46	51	54
	6925	4074	65	60	64	50	55	57
24 x 16	6630	3900	56	60	67	52	55	60
	8216	4833	57	61	68	56	58	62
	9802	5766	59	63	71	59	61	64
	11388	6699	61	71	72	61	64	67

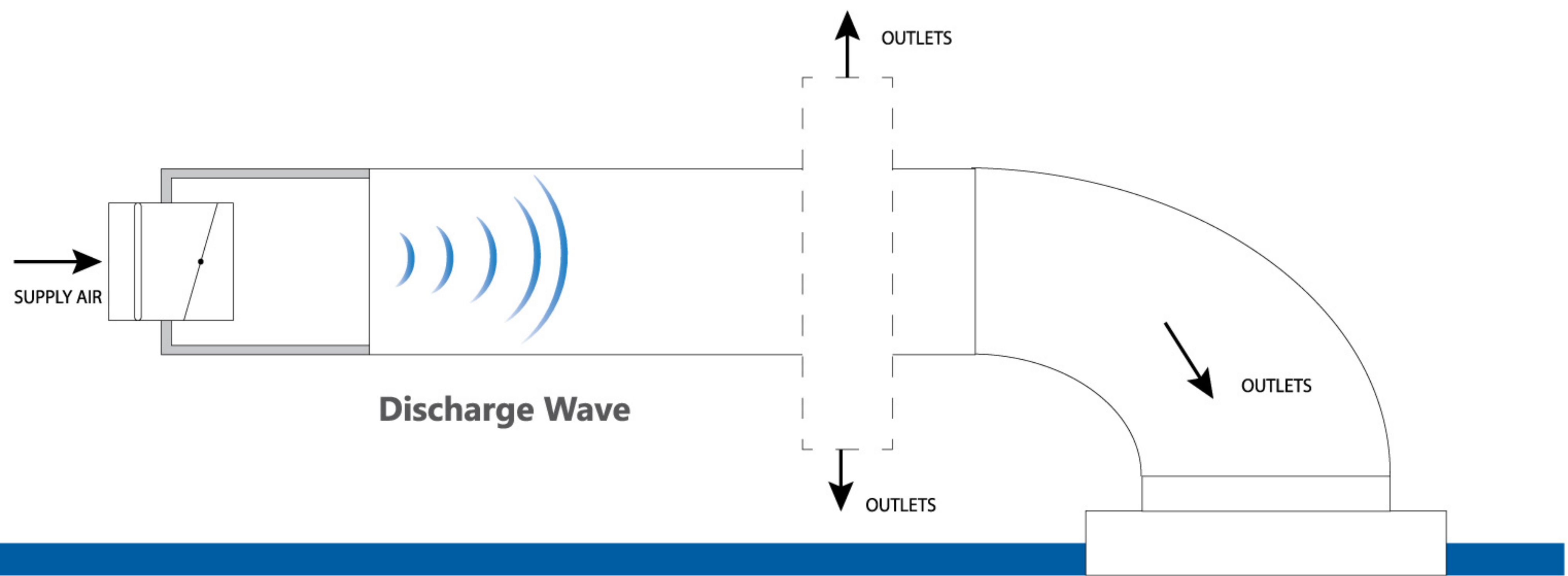

System Noise Correction (10 dB/Oct):

- i) Duct bend attenuation
- ii) Room attenuation
- iii) End Reflection based on diffuser
- iv) Ceiling Reduction
- v) Air distribution between several diffusers

TECHNICAL PERFORMANCE DATA

ACOUSTIC DATA - DISCHARGE SOUND - BASE TERMINAL UNIT

	Airflow		Sound Pressure Level (Lw dB)																					
			△ Ps 100Pa							△ Ps 200Pa							△ Ps 500Pa							
			Oct. Band Centre Freq.							Oct. Band Centre Freq.							Oct. Band Centre Freq.							
CMH	CFM	125	250	500	1000	2000	4000	NR	125	250	500	1000	2000	4000	NR	125	250	500	1000	2000	4000	NR		
4.0	75	44	63	55	42	36	34	26	37	65	45	40	35	35	33	39	62	53	47	46	46	44	39	
	124	73	68	53	45	41	39	32	43	70	56	48	43	43	38	45	72	61	55	50	50	49	47	
	231	136	72	62	52	46	44	36	47	74	65	55	50	49	42	50	77	69	62	58	58	54	53	
	340	200	77	68	58	53	48	40	53	79	71	61	56	53	45	56	81	75	68	63	62	57	58	
5.0	111	65	61	43	41	37	37	29	35	61	50	52	37	37	36	35	67	54	53	47	47	46	42	
	226	133	67	53	47	43	41	34	42	69	57	51	46	45	40	44	73	63	59	54	54	50	49	
	410	241	73	61	54	50	46	39	49	75	65	58	54	51	44	51	80	71	66	61	60	56	57	
	593	349	77	65	58	54	49	41	53	79	69	62	58	55	46	56	83	76	70	64	63	58	60	
6.0	127	75	46	42	37	33	30	27	23	53	48	43	43	38	31	33	55	54	48	41	40	48	43	
	372	219	46	44	41	39	36	31	29	54	49	48	43	40	36	34	58	59	52	43	44	50	45	
	650	382	48	47	43	37	39	33	32	55	51	47	45	43	39	36	60	61	56	45	46	53	48	
	930	547	60	42	39	41	33	28	33	60	53	49	49	47	41	40	63	60	59	47	48	56	51	
8.0	175	103	46	41	37	33	30	28	23	52	48	43	43	38	32	33	58	57	54	44	42	47	42	
	680	400	48	45	42	40	36	32	30	54	50	46	44	41	37	34	61	59	57	45	46	52	47	
	1190	700	50	49	45	39	40	34	32	57	53	49	46	44	40	37	62	60	58	47	48	54	49	
	1700	1000	53	45	40	43	36	30	33	60	55	51	49	47	42	40	64	62	61	49	50	57	52	
10.0	270	159	46	42	39	34	32	30	25	51	48	44	43	39	34	33	57	60	58	48	47	51	46	
	1080	635	50	48	46	43	39	35	33	56	52	49	47	43	40	37	61	62	61	50	48	53	48	
	1890	1111	54	53	50	43	43	39	36	60	57	53	50	47	44	40	64	63	64	53	51	57	51	
	2700	1588	58	52	49	49	42	38	39	63	59	56	51	48	46	42	67	66	65	54	55	60	55	
12.0	370	218	46	43	40	35	34	32	27	50	48	45	43	40	36	33	63	64	62	55	53	54	49	
	1470	865	53	52	50	46	41	38	36	58	55	52	49	46	43	39	65	66	64	56	57	59	54	
	2575	1515	60	58	56	49	47	44	42	64	61	58	54	50	48	44	67	69	66	58	59	62	56	
	3680	2165	64	61	59	57	50	47	47	64	64	61	56	52	51	48	70	71	69	61	61	64	58	
14.0	525	309	46	44	42	37	37	35	30	48	49	46	44	41	40	35	66	58	51	60	51	44	50	
	2090	1229	59	58	56	51	46	44	42	62	60	58	54	50	47	44	70	68	65	63	61	60	55	
	3670	2158	68	67	65	57	53	53	52	70	69	67	61	56	56	54	73	74	71	67	65	65	59	
	5240	3082	73	75	75	69	63	62	62	72	76	76	68	56	64	63	75	79	77	72	70	69	64	
16.0	693	408	46	44	43	38	40	38	33	47	50	47	44	42	43	38	55	58	55	58	52	56	51	
	2770	1629	63	63	61	55	49	48	48	65	64	63	57	53	51	50	68	70	68	64	61	61	55	
	4850	2853	74	71	69	59	52	54	56	72	70	67	59	54	54	54	74	76	70	65	63	62	59	
	6925	4074	78	80	78	65	59	62	65	75	77	73	63	58	59	60	77	81	74	67	65	64	64	
24x16	693	408	46	44	43	38	40	38	33	47	50	47	44	42	43	38	55	58	55	58	52	56	51	
	2770	1629	63	63	61	55	49	48	48	65	64	63	57	53	51	50	68	70	68	64	61	61	55	
	4850	2853	74	71	69	59	52	54	56	72	70	67	59	54	54	54	74	76	70	65	63	62	59	
	6925	4074	78	80	78	65	59	62	65	75	77	73	63	58	59	60	77	81	74	67	65	64	64	

* NC / NR level conversion takes into account of System Noise Correction of 10dB/Oct.

* "-" indicates values lower than 15

* "Ps" indicates the Static Pressure Drop across the Terminal Unit.

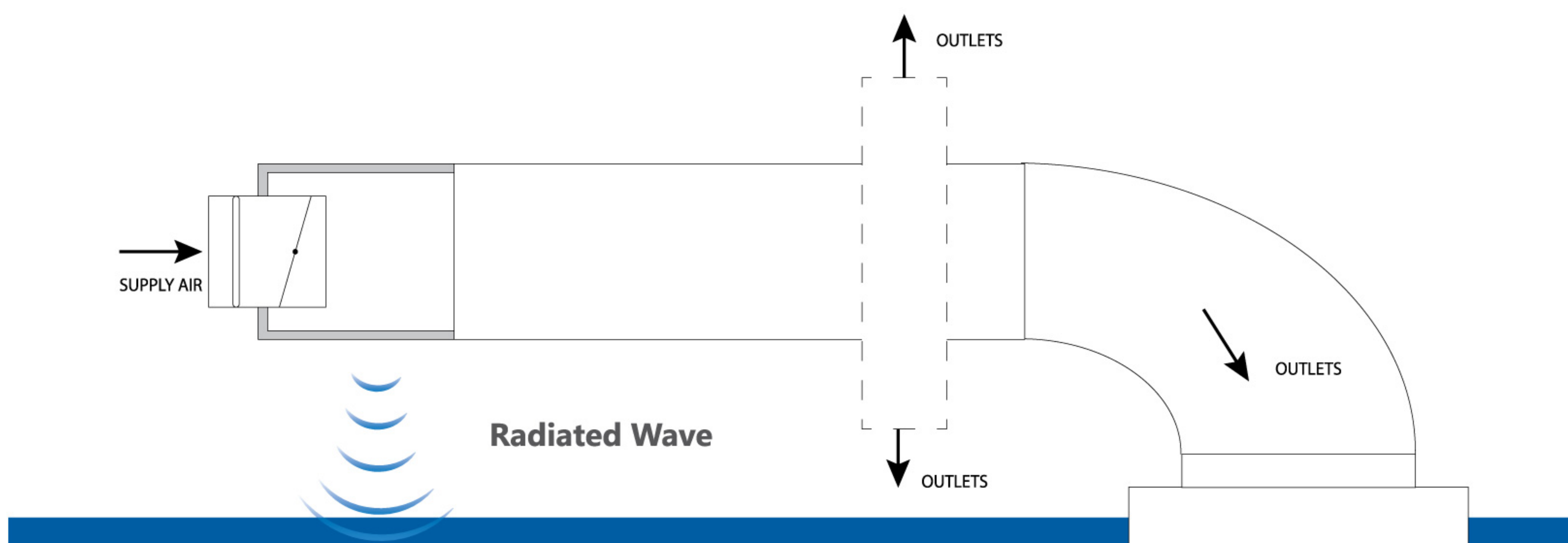

System Noise Correction (10 dB/Oct):

- i) Duct bend attenuation
- ii) Room attenuation
- iii) End Reflection based on diffuser
- iv) Ceiling Reduction
- v) Air distribution between several diffusers

ACOUSTIC DATA - RADIATED SOUND - BASE TERMINAL UNIT

	Airflow		Sound Pressure Level (Lw dB)																					
			△ Ps 100Pa							△ Ps 200Pa							△ Ps 500Pa							
			Oct. Band Centre Freq.							Oct. Band Centre Freq.							Oct. Band Centre Freq.							
CMH	CFM	125	250	500	1000	2000	4000	NR	125	250	500	1000	2000	4000	NR	125	250	500	1000	2000	4000	NR		
4.0	75	44	38	27	26	25	23	22	18	37	34	30	29	29	26	22	45	38	37	35	30	29	25	
	124	73	46	40	34	32	30	25	23	47	44	36	35	35	29	28	53	48	43	37	33	31	29	
	231	136	54	52	42	38	34	27	33	56	54	44	40	37	33	35	60	58	48	43	43	40	39	
	340	200	60	58	45	41	37	30	39	63	61	48	44	40	35	43	67	65	53	47	46	43	47	
5.0	111	65	39	34	29	25	24	20	17	42	38	33	28	27	21	20	51	44	40	34	34	32	27	
	226	133	48	43	35	32	30	24	23	51	47	40	35	34	28	28	57	54	46	40	40	36	35	
	410	241	55	52	42	38	37	29	33	58	56	46	41	39	34	37	64	63	53	46	45	41	45	
	593	349	60	57	46	41	39	32	38	63	61	49	44	42	36	43	68	67	56	49	47	43	49	
6.0	127	75	39	34	26	39	18	-	19	40	40	31	35	24	-	25	45	48	45	42	39	38	33	
	372	219	46	43	34	31	22	-	23	49	49	38	36	27	-	30	57	58	54	48	42	42	40	
	650	382	53	46	39	38	23	-	28	56	52	41	43	28	18	33	64	62	54	52	47	46	43	
	930	547	56	50	38	40	27	-	31	58	55	41	46	29	20	36	67	63	55	53	47	45	44	
8.0	175	103	39	35	26	29	20	-	19	40	39	31	35	24	-	25	38	42	34	39	26	24	29	
	680	400	47	44	36	33	24	-	24	50	49	43	37	29	21	30	55	51	46	42	33	30	32	
	1190	700	56	51	44	41	27	28	32	58	51	44	44	40	28	34	68	55	46	40	39	34	43	
	1700	1000	58	56	50	47	39	37	37	61	56	50	48	45	32	38	71	56	59	46	45	37	46	
10.0	270	159	39	36	28	28	19	-	18	41	41	32	35	25	17	25	46	45	37	43	31	23	33	
	1080	635	50	48	40	37	29	-	29	52	52	43	41	33	26	33	66	60	47	50	38	32	41	
	1890	1111	58	55	40	46	39	33	36	62	58	53	48	41	35	39	71	65	50	52	42	34	47	
	2700	1588	63	57	52	48	46	46	41	64	62	55	52	50	45	43	75	66	53	59	46	37	51	
12.0	370	218	40	37	30	28	-	-	18	42	42	33	35	25	-	24	47	48	39	42	32	25	32	
	1470	865	45	42	37	36	36	33	29	55	55	47	45	38	32	36	65	62	51	53	41	34	43	
	2575	1515	61	54	54	50	45	44	40	63	62	65	51	43	36	43	70	67	54	55	43	36	49	
	3680	2165	63	59	59	57	50	47	47	71	68	59	57	53	51	50	75	72	57	57	47	38	54	
14.0	525	309	41	40	33	28	-	-	21	44	44	35	33	27	21	24	61	60	51	48	51	46	44	
	2090	1229	59	58	53	50	-	-	40	67	65	53	44	46	40	43	69	68	62	59	54	50	50	
	3670	2158	57	61	59	55	53	53	48	68	66	63	58	55	47	50	74	73	65	51	56	52	56	
	5240	3082	70	66	64	58	58	56	51	70	69	66	61	56	52	53	79	78	68	63	60	54	61	
16.0	693	408	41	41	35	27	21	-	21	45	45	36	33	27	22	26	57	55	44	42	44	41	37	
	2770	1629	56	55	43	32	24	17	36	64	63	60	57	52	49	47	69	68	64	61	56	53	51	
	4850	2853	64	64	51	42	34	25	46	68	65	60	58	57	56	51	73	72	65	63	56	54	54	
	6925	4074	66	68	56	48	39	35	50	74	69	67	60	62	59	55	76	74	67	65	58	54	57	
24x16	693	408	70	66	64	61	59	56	52	72	69	68	64	62	59	55	77	72	71	67	67	66	60	
	2770	1629	74	70	69	65	62	57	56	77	73	71	67	65	61	58	81	76	75	71	70	68	62	
	4850	2853	77	73	72	67	64	59	59	80	75	74	69	67	63	61	83	78	77	74	72	70	64	
	6925	4074	80	76	74	69	66	60	61	83	78	77	72	69	64	64	86	81	80	76	75	71	67	

* NC / NR level conversion takes into account of System Noise Correction of 10dB/Oct. * "-" indicates values lower than 15 * "Ps" indicates the Static Pressure Drop across the Terminal Unit.

TECHNICAL PERFORMANCE DATA

STANDARD ELECTRIC REHEAT COIL SELECTION

Order Size (inch)	Airflow Range CMH	Stages	Allowable Maximum kW					
			1 Phase			3 Phase		
			120V	240V	277V	208V	415V	600V
4.0	75 - 340	1, 2	5.0	6.0	6.0	6.0	6.0	6.0
5.0	111 - 793	1, 2	5.0	6.0	6.0	6.0	6.0	6.0
6.0	127 - 945	1, 2	5.0	6.0	6.0	6.0	6.0	6.0
8.0	170 - 1675	1, 2, 3	5.0	9.5	11.0	11.0	11.0	11.0
10.0	245 - 2450	1, 2, 3	5.0	11.5	13.0	17.0	17.0	17.0
12.0	350 - 3475	1, 2, 3	5.0	11.5	13.0	17.0	30.0	30.0
14.0	500 - 4990	1, 2, 3	5.0	11.5	13.0	17.0	34.5	49.5
16.0	640 - 6320	1, 2, 3	5.0	11.5	13.0	17.0	34.5	49.5
24 x 16	640 - 6320	1, 2, 3	5.0	11.5	13.0	17.0	34.5	49.5

RECOMMENDED INSTALLATION METHOD

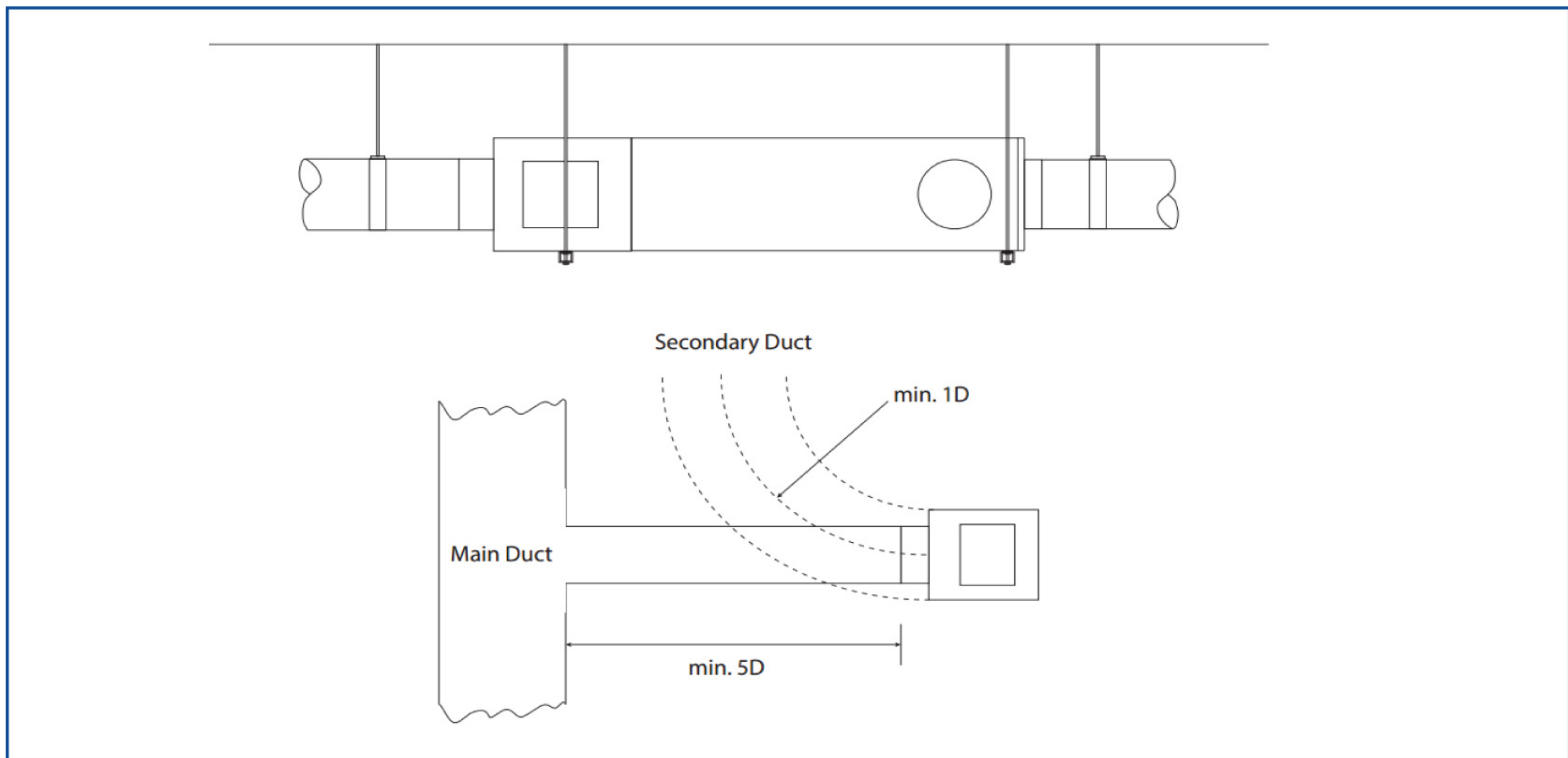

Installation Instructions:

1. The VAV terminals shall be installed at least two support brackets (One for the base unit, the other for accessories if any). Each of these brackets shall be fixed with two threaded rods to the ceiling slabs above.
2. Recommended entry flow conditions as followed :
 - i. Min 5D from main duct
 - ii. Min 1D radius from secondary duct
3. Additional volume control dampers before the inlet are required / recommended.
4. All connections shall be thermally isolated
5. Pressure sensing tubes of the flow sensor shall not be 'kinked' or otherwise obstructed by the external duct insulation.

PRODUCT SELECTION CHECKLIST

1. Select unit inlet size based on control and acoustic parameters
2. Select control type :
 - i) Standalone
 - ii) BACNet
 - iii) LONWorks
4. Select reheat coil, fan (if required)
5. Select control sequence based on system design

General

- a. Variable Air Volume (VAV) terminal units shall be factory assembled, consisting of a sound reducing air chamber, round inlet spigot, tight seal damper blade, and rectangular outlet for duct connection. VAV boxes shall be provided for areas as indicated on the drawings and equipment schedule.
- b. VAV boxes shall be rectangular or circular type, DDC (Direct Digital Control) controlled pressure independent designed for accurate measurement and control of volume airflow.
- c. VAV boxes shall be supplied complete with controllers, actuators and sensors by the VAV manufacturer to ensure single source responsibility for the unit performance. VAV terminal units shall be LON, BACnet or standalone compatible.
- d. The VAV unit shall be product of a single manufacturer certified to ISO9001 for the manufacturer of such equipment. The controller and actuator, if not originally manufacturer by the VAV manufacturer shall be product of a single manufacturer certified to ISO9001 for the manufacturer of control equipment to ensure compatibility.
- e. VAV units and wind tunnel performance data submitted shall be tested in accordance to ISO130-20098, ISO120-1999 or equivalent. The manufacturer's wind tunnel laboratory shall be available for viewing by relevant bodies upon request.
- f. Factory calibration of VAV units to be done by manufacturer before delivering. The warranty of the complete unit including the controls shall be the sole responsibility of the supplier.

Construction

- a. VAV terminal units shall be supplied in 6 nominal sizes (6.0", 10.0", 12.0", 14.0", 24.0" x 16.0"). VAV manufacturer shall have the flexibility to supply customizable inlet and outlet spigot sizes with relevant factory performance test.
- b. Multi-outlet arrangements of A-Z shall be available upon customer request. The unit shall have proper opening with collar to enable connection of flexible ducts. Manual-throttling damper for airflow balancing to be provided for each outlet spigot upon customer request. Stainless steel construction shall be available upon customer request.
- c. VAV casing shall be air-tight construction made of galvanized steel not less than 24 gauge (0.6mm) with internal insulation of at least 25mm thickness.
- d. Damper blades shall be of no less than 1.6mm thickness (double skin), with peripheral tear resistant Neoprene lip seal to ensure minimum leakage at a closed position. Damper shaft shall have damper position indicator to indicate the blade's current position. All control components shall be mounted inside a protective metal shroud attached to the VAV unit.
- e. Damper blades shall be able to travel continuously from range of 0 to 60 Deg as to provide more linear flow characteristic and hence more precise modulation of air flow.
- f. Access door shall be provided upon customer request. Access door shall be insulation to ensure minimum air leakage during operation.
- g. Airflow sensors shall be constructed of a special profile capable of significantly amplifying the velocity signal to improve reading accuracy even at low air velocity. Averaging chamber shall be provided for accurate flow measurement.
- h. Airflow sensors of nominal VAV sizes (excluding 6.0") shall have a minimum of 30 (2x15) test points and the position of the test points shall be arranged to ensure a true average measurement signal. Factory performance test shall be submitted to verify the airflow sensor accuracy.

DDC Controller

- a. The DDC controller shall be fully functional and shall be of the type that operates on open system concept (such as Lonworks for ready interfacing and freely integrating with the building's Lon based Building Automation System BAS), without any. The controller shall be capable of stand-alone and networking operation.
- b. The integral damper actuator shall be minimum 5Nm torque, over the shaft mounting type. Stroke shall be fully adjustable from 0-94 Deg rotation with visible position indicator.
- c. Integral transforms shall be provided for each VAV units to provide power supply for the controller.







Performance

- a. The static pressure drop across the VAV terminal units at maximum catalogue airflow shall not exceed 70 Pa. the throttling range shall be from 100-10%
- b. Airflow sensors shall be capable of amplifying the velocity signal by at least 2.0 times to improve reading accuracy at low air velocity.
- c. Air leakage through the damper shall be within 2% tolerance at an inlet static pressure of 750 Pa of nominal air flow.
- d. Independent of inlet pressure variations, VAV units shall modulate the delivered air volume between the specified maximum and minimum air volume with accuracy of the flow performance within +/-5% tolerance even with irregular duct approach.
- e. The noise level in the air-conditioned areas shall not exceed that as specified.



VAV | Variable Air Volume Box

Products Range

- Grilles 
- Diffusers 
- Dampers 
- Fire & Smoke Protection 
- VAV 
- Others 
- Accessories 



Prudent Aire Sdn Bhd 514037-D
 Lot 2102, Jalan KPB12, Off Jalan Suria Park 1, Kg Baru Balakong,
 43300 Seri Kembangan, Selangor Darul Ehsan, Malaysia
 Tel : +603-9100 3858 (HL) / 9101 3869 / 9101 5868
 Fax : +603-9100 4868 Email : sales@prudentaire.com

www.prudentaire.com